



Ethernet Packet Generator  
**Header Definitions**  
Version 1.1.1



**APG4 APG8 APG200 APG208**

## Software Revisions

This document applies to the following software versions:

<b>APG Unit Firmware</b>	<b>Version 2.3</b>
<b>APG Processing Core</b>	<b>Version 6.010E (10Gbps)</b> <b>Version 7.0103 (1Gbps)</b> Datecode: 01 March 2019
<b>APG Control Interface</b>	<b>Version 2.2</b>
<b>APG TCL API</b>	<b>Version 1.2.2</b>

## Revision History

Date	Version	Changes
10 August 2016	1.0	<ul style="list-style-type: none"> <li>• First customer release</li> </ul>
8 February 2018	1.1	<ul style="list-style-type: none"> <li>• Merged Layer 2+ and Type layers (Section 3)</li> <li>• Corrected VLAN Protocol ID field label to TPID and set to editable (Section 3.1)</li> <li>• Added Layer 3 IPV4 Header (Section 4.1)</li> <li>• Added Layer 3 IPV6 Header (Section 4.2)</li> <li>• Added Layer 4 ESP Header (Section 5.1)</li> <li>• Added Layer 4 GRE Header (Section 5.2)</li> <li>• Moved User Defined Header descriptions (Section 6)</li> </ul>
4 September 2019	1.1.1	<ul style="list-style-type: none"> <li>• Corrected ETHERNET_II (underscore not hyphen)</li> </ul>

## Related Documentation

- [1] APG-UG            Axtrinet User Guide (including APG Control Interface)
- [2] APG-TCL-UG    Axtrinet TCL API User Guide
- [3] APG-SW-TC     Axtrinet APG Software License Terms And Conditions

Visit [www.axtrinet.com/downloads](http://www.axtrinet.com/downloads) for the latest documentation.

## Disclaimer

Axtrinet retains the right to make changes to this document at any time, without notice. The information in this document is believed to be accurate and reliable. Axtrinet does not warrant the accuracy of completeness of the information, text, graphics or other items contained within this document.

Axtrinet provides the software and the documentation "as is" without warranties of any kind.

Axtrinet disclaims all warranties and representations of any kind relating to products, software or services provided hereunder, whether express, implied, statutory, including without limitation the implied warranties of merchantability, fitness for a particular purpose, accuracy, or non-infringement of third party rights.

Axtrinet does not warrant that the software will in every case process all data correctly, or that operation of the products, including software, will be uninterrupted, free from error, or secure.

The disclaimers in this section will not apply to the extent prohibited by applicable law.

The software is not designed, intended, or certified for use in components of systems intended for the operation of weapons, weapons systems, nuclear installations, means of mass transportation, aviation, medical systems, devices, implants, or equipment, pollution control, hazardous substances management, or for any other dangerous application in which the failure of the products could create a situation where bodily injury or death may occur. The use of the software in any such application is solely at your own risk.

## Copyright statement

Copyright © 2016-2019 Xentech Solutions Limited, all rights reserved. The information contained in this document is the property of Xentech Solutions Limited. No part of this publication shall be reproduced, stored or transmitted in any form or by any means without the prior written permission of Xentech Solutions Limited.

Axtrinet™ is a trading name and registered trademark of Xentech Solutions Ltd.

## Contents

<b>1.</b>	<b>INTRODUCTION .....</b>	<b>5</b>
<b>1.1</b>	<b>Supported Headers .....</b>	<b>5</b>
<b>1.2</b>	<b>Header Styles .....</b>	<b>5</b>
<b>2.</b>	<b>LAYER 2 HEADERS .....</b>	<b>6</b>
<b>2.1</b>	<b>MACHEADER .....</b>	<b>6</b>
<b>2.2</b>	<b>PAUSE.....</b>	<b>6</b>
<b>2.3</b>	<b>USERDEFINED.....</b>	<b>6</b>
<b>2.4</b>	<b>USERDEFINED16.....</b>	<b>6</b>
<b>3.</b>	<b>LAYER 2+ HEADERS .....</b>	<b>7</b>
<b>3.1</b>	<b>VLAN_INNER .....</b>	<b>7</b>
<b>3.2</b>	<b>VLAN_OUTER .....</b>	<b>7</b>
<b>3.3</b>	<b>ETHERNET-II .....</b>	<b>7</b>
<b>3.4</b>	<b>MPLS.....</b>	<b>7</b>
<b>3.5</b>	<b>USERDEFINED.....</b>	<b>7</b>
<b>3.6</b>	<b>USERDEFINED16.....</b>	<b>7</b>
<b>4.</b>	<b>LAYER 3 HEADERS .....</b>	<b>8</b>
<b>4.1</b>	<b>IPV4_HEADER.....</b>	<b>8</b>
<b>4.2</b>	<b>IPV6_HEADER.....</b>	<b>8</b>
<b>4.3</b>	<b>ARP_HEADER.....</b>	<b>9</b>
<b>4.4</b>	<b>USERDEFINED.....</b>	<b>9</b>
<b>4.5</b>	<b>USERDEFINED16.....</b>	<b>9</b>
<b>5.</b>	<b>LAYER 4 HEADERS .....</b>	<b>10</b>
<b>5.1</b>	<b>ESP .....</b>	<b>10</b>
<b>5.2</b>	<b>GRE.....</b>	<b>10</b>
<b>5.3</b>	<b>USERDEFINED.....</b>	<b>10</b>
<b>5.4</b>	<b>USERDEFINED16.....</b>	<b>10</b>
<b>6.</b>	<b>USER DEFINED HEADERS .....</b>	<b>11</b>
<b>6.1</b>	<b>USERDEFINED.....</b>	<b>11</b>
<b>6.2</b>	<b>USERDEFINED16.....</b>	<b>11</b>

# 1. INTRODUCTION

The Axtrinet Packet Generators use a header definition to determine the header types, fields and expected structure within the Ethernet packet.

In a valid Ethernet packet, the headers identify the Network Layers in the OSI Model.

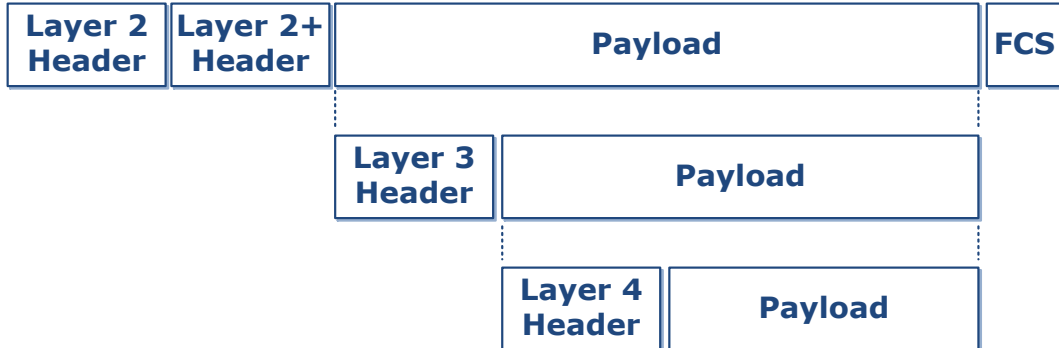

## 1.1 SUPPORTED HEADERS

The following headers are supported by the APG Control Interface and APG TCL API:

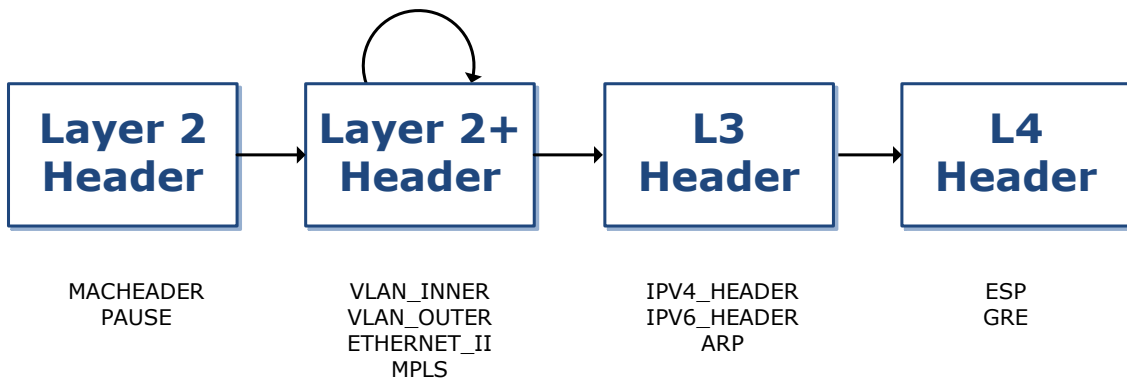

## 1.2 HEADER STYLES

Each header variable has a STYLE that defines the format, minimum and maximum values.

The following styles are used:

[STYLE]	Length	Min	Max
<b>MAC-ADDRESS</b>	17 chars	0:0:0:0:0:0	FF:FF:FF:FF:FF:FF
<b>INT</b>	Variable	0	
<b>HEX2</b>	1 byte	0x0	0xFF
<b>HEX4</b>	2 bytes	0x0	0xFFFF
<b>HEX8</b>	4 bytes	0x0	0xFFFFFFFF
<b>HEX2ARRAY</b>	Variable	0x0	0xFF
<b>IPV4-ADDRESS</b>	4 bytes	0.0.0.0	255.255.255.255
<b>IPV6-ADDRESS</b>	16 bytes	0:0:0:0:0:0:0:0	FFFF:FFFF:FFFF:FFFF:FFFF:FFFF:FFFF:FFFF

## 2. LAYER 2 HEADERS

### 2.1 MACHEADER

Editable →

LABEL	DESCRIPTION	SIZE	STYLE	ED	DEFAULT	MODES	Default
<b>DA</b>	MAC Destination Address	6 bytes	mac-address	1	0:0:0:0:0:0	FIX INC DEC RND	FIX
<b>SA</b>	MAC Source Address	6 bytes	mac-address	1	0:0:0:0:0:0	FIX INC DEC RND	FIX

Where:  
 FIX = Fixed  
 INC = Incrementing  
 DEC = Decrementing  
 RND = Random

### 2.2 PAUSE

LABEL	DESCRIPTION	SIZE	STYLE	ED	DEFAULT	MODES	Default
<b>DA</b>	MAC Destination Address	6 bytes	mac-address	0	1:80:C2:0:0:1	-	-
<b>SA</b>	MAC Source Address	6 bytes	mac-address	1	0:0:0:0:0:0	-	-
<b>TYPE</b>	Ethertype	2 bytes	hex4	0	0x8808	-	-
<b>OPCODE</b>	Control Opcode	2 bytes	hex4	0	0x0001	-	-
<b>QUANTA</b>	Pause Quanta	2 bytes	int	1	0x0001	-	-

### 2.3 USERDEFINED

### 2.4 USERDEFINED16

See Section 6

## 3. LAYER 2+ HEADERS

### 3.1 VLAN\_INNER

LABEL	DESCRIPTION	SIZE	STYLE	ED	DEFAULT	MODES	Default
<b>TPID</b>	Protocol ID	2 bytes	HEX4	1	0x8100	-	-
<b>PRIORITY</b>	User Priority	3 bits	INT	1	0	-	-
<b>CFI</b>	Canonical Format Indicator	1 bit	INT	1	0	-	-
<b>VID</b>	VLAN Identifier	12 bits	INT	1	1	FIX INC DEC RND	FIX

### 3.2 VLAN\_OUTER

LABEL	DESCRIPTION	SIZE	STYLE	ED	DEFAULT	MODES	Default
<b>TPID</b>	Protocol ID	2 bytes	HEX4	1	0x9100	-	-
<b>PRIORITY</b>	User Priority	3 bits	INT	1	0	-	-
<b>CFI</b>	Canonical Format Indicator	1 bit	INT	1	0	-	-
<b>VID</b>	VLAN Identifier	12 bits	INT	1	1	FIX INC DEC RND	FIX

Note:

- VLAN\_INNER and VLAN\_OUTER have different default TPID values only.
- For a Service Tag (S-Tag), set TPID to 0x88A8

### 3.3 ETHERNET\_II

LABEL	DESCRIPTION	SIZE	STYLE	ED	DEFAULT	MODES	Default
<b>ETHERTYPE</b>	Encapsulated protocol ID	2 bytes	hex4	1	0x800	-	-

Note:

- When using the Control Interface, the ETHERTYPE field may be configured automatically depending on the next header type, eg an MPLS header will set the ETHERTYPE to 0x8847
- When using the TCL API, the ETHERTYPE field is never configured automatically

### 3.4 MPLS

LABEL	DESCRIPTION	SIZE	STYLE	ED	DEFAULT	MODES	Default
<b>LABEL</b>	Label value	20 bits	int	1	16	-	-
<b>TC</b>	Traffic Class	3 bits	int	1	0	-	-
<b>S</b>	Bottom of Stack	1 bit	int	1	1	-	-
<b>TTL</b>	Time to Live	1 byte	int	1	64	-	-

### 3.5 USERDEFINED

### 3.6 USERDEFINED16

See Section 6

## 4. LAYER 3 HEADERS

### 4.1 IPV4\_HEADER

LABEL	DESCRIPTION	SIZE	STYLE	ED	DEFAULT	MODES	Default
<b>VERSION</b>	Version Field	4 bits	int	0	4	-	-
<b>IHL</b>	Internet Header Length	4 bits	int	0	5	-	-
<b>DSCP</b>	Differentiated Services Code Point	6 bits	int	1	0	-	-
<b>ECN</b>	Explicit Congestion Notification	2 bits	int	1	0	-	-
<b>TOTAL_LENGTH</b>	Total IP Packet Length	2 bytes	int	1	0	-	-
<b>IDENTIFICATION</b>	Identification Field	2 bytes	int	0	0	-	-
<b>FLAGS</b>	Fragment Flags	3 bits	int	1	0	-	-
<b>FRAGMENT_OFFSET</b>	Fragment Offset	13 bits	int	1	0	-	-
<b>TTL</b>	Time to Live	1 byte	int	1	0	-	-
<b>PROTOCOL</b>	IP Protocol Number	1 byte	hex2	1	0x00	-	-
<b>CHECKSUM</b>	Header Checksum	2 bytes	hex4	0	0x0000	-	-
<b>SOURCE</b>	Source IP Address	4 bytes	ipv4-address	1	0.0.0.0	-	-
<b>DESTINATION</b>	Destination IP Address	4 bytes	ipv4-address	1	0.0.0.0	-	-

Note:

- When using the Control Interface, the TOTAL\_LENGTH and CHECKSUM can be calculated automatically by checking the corresponding Length and Checksum checkboxes. The values are calculated **once** for a **fixed length** packet. Calculated TOTAL\_LENGTHs and CHECKSUMs will be incorrect for variable length (random, incrementing, decrementing) packet lengths. If the checkboxes are unchecked, the TOTAL\_LENGTH and CHECKSUM values can be entered manually.
- When using the TCL API, the automatic TOTAL\_LENGTH and CHECKSUM calculation is not available. Values must be entered manually.

### 4.2 IPV6\_HEADER

LABEL	DESCRIPTION	SIZE	STYLE	ED	DEFAULT	MODES	Default
<b>VERSION</b>	Version Field	4 bits	int	0	6	-	-
<b>DS</b>	Differentiated Services	6 bits	hex2	1	0	-	-
<b>ECN</b>	Explicit Congestion Notification	2 bits	int	1	0	-	-
<b>FLOW_LABEL</b>		20 bits	int	1	0	-	-
<b>PAYLOAD_LENGTH</b>		2 bytes	int	1	0	-	-
<b>NEXT_HEADER</b>	Next header type	1 byte	hex2	1	0	-	-
<b>HOP_LIMIT</b>		1 byte	int	1	0	-	-
<b>SOURCE</b>	Source IP Address	16 bytes	ipv6-address	1	0:0:0:0:0:0:0:0	-	-
<b>DESTINATION</b>	Destination IP Address	16 bytes	ipv6-address	1	0:0:0:0:0:0:0:0	-	-

Note:

- When using the Control Interface, the PAYLOAD\_LENGTH can be calculated automatically by checking the Length checkbox. The value is calculated **once** for a **fixed length** packet. Calculated PAYLOAD\_LENGTH will be incorrect for variable length (random, incrementing, decrementing) packet lengths. If the checkboxes are unchecked, the PAYLOAD\_LENGTH value can be entered manually.
- When using the TCL API, the automatic PAYLOAD\_LENGTH calculation is not available. The value must be entered manually.



### 4.3 ARP\_HEADER

LABEL	DESCRIPTION	SIZE	STYLE	ED	DEFAULT	MODES	Default
<b>HTYPE</b>	Header Type	2 bytes	hex4	0	0x1	-	-
<b>PTYPE</b>	Protocol Type	2 bytes	hex4	0	0x0800	-	-
<b>HLEN</b>	Header Length	1 byte	hex2	0	0x6	-	-
<b>PLEN</b>	Protocol Length	1 byte	hex2	0	0x4	-	-
<b>OPERATION</b>	Operation	2 bytes	int	1	1	-	-
<b>SHA</b>	Sender Header Address	6 bytes	mac-address	1	0	FIX INC DEC RND	FIX
<b>SPA</b>	Sender Protocol Address	4 bytes	ipv4-address	1	0 0 0 0	FIX INC DEC RND	FIX
<b>THA</b>	Target Protocol Header	6 bytes	mac-address	1	0	FIX INC DEC RND	FIX
<b>TPA</b>	Target Protocol Address	4 bytes	ipv4-address	1	0 0 0 0	FIX INC DEC RND	FIX

### 4.4 USERDEFINED

### 4.5 USERDEFINED16

See Section 6

## 5. LAYER 4 HEADERS

### 5.1 ESP

LABEL	DESCRIPTION	SIZE	STYLE	ED	DEFAULT	MODES	Default
<b>SPI</b>	Security Parameters Index	4 bytes	int	1	0	-	-
<b>SEQUENCE_NUMBER</b>		4 bytes	int	1	0	-	-

### 5.2 GRE

LABEL	DESCRIPTION	SIZE	STYLE	ED	DEFAULT	MODES	Default
<b>CHECKSUM_PRESENT</b>	-	1 bit	int	1	0	-	-
<b>RESERVED</b>	-	1 bit	int	0	0	-	-
<b>KEY_PRESENT</b>	-	1 bit	int	1	0		
<b>SEQUENCE_PRESENT</b>	-	1 bit	int	1	0	-	-
<b>RESERVED1</b>	-	9 bits	int	0	0	-	-
<b>VERSION</b>	-	3 bits	int	0	0		
<b>PROTOCOL</b>	-	2 bytes	hex4	1	0	-	-
<b>CHECKSUM</b>	-	2 bytes	hex4	0	0	-	-
<b>RESERVED2</b>	-	2 bytes	hex4	0	0		
<b>KEY</b>	-	4 bytes	hex8	1	0	-	-
<b>SEQUENCE_NUMBER</b>	-	4 bytes	int	1	0	-	-

### 5.3 USERDEFINED

### 5.4 USERDEFINED16

See Section 6

## 6. USER DEFINED HEADERS

User-defined field can be used anywhere within the header structure to allow undefined headers to be incorporated into the packet header.

USERDEFINED headers are fixed length, fixed payload headers.

USERDEFINED16 headers are 16-bit variable content headers.

### 6.1 USERDEFINED

LABEL	DESCRIPTION	SIZE	STYLE	ED	DEFAULT	MODES	Default
<b>LENGTH</b>	Byte Length of User Defined Data	2 bytes	int	1	16	-	-
<b>DATA</b>	Byte Data	LENGTH	hex2array	1	-	-	-

Note:

- When using the Control Interface, the LENGTH field defined the number of bytes that can be entered in the DATA box. DATA is truncated if the number of DATA bytes is greater than LENGTH.
- When using the TCL API, the LENGTH field is calculated automatically from the configured DATA.

### 6.2 USERDEFINED16

LABEL	DESCRIPTION	SIZE	STYLE	ED	DEFAULT	MODES	Default
<b>DATA</b>	Byte Data	2 bytes	hex4	1	-	FIX INC	FIX



Xentech Solutions Ltd  
Suite 6 Stanta Business Centre  
3 Soothouse Spring  
St Albans  
AL3 6PF  
United Kingdom

Tel: +44 (0)1727 867795  
Email: [support@axtrinet.com](mailto:support@axtrinet.com)